

ONwheel
powered by go-e

Complete Kit

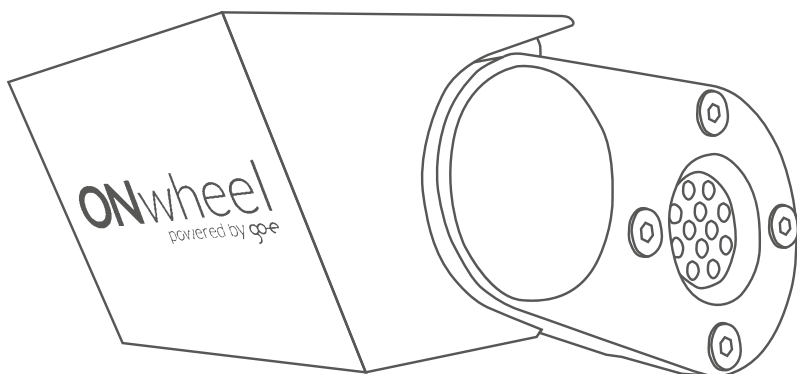

EN
User manual

Index

Safety Instructions	3
Speed Control.....	3
Working with the ONwheel.....	3
Working with the battery.....	4
Working with the charger.....	4
Working with the Power Grip (accelerator throttle).....	5
CE-Declaration of Conformity	6
Machinery Directive.....	7
Delivery contents	8
Included in delivery.....	8
Optional available products.....	9
Mounting and setting up the ONwheel Complete Kit.....	10
Preparation of mounting.....	10
Step 1: Mounting plate fixation	10
Step 2: Speed Sensor fixation	12
Step 3: Battery holder fixation.....	13
Step 4: Laying the Power Button cable	13
Step 5: PAS Sensor - magnetic ring/magnetic disk fixation	14
Fixation type 1	
Fixation type 2	
Fixation type 3	
Step 6: ONwheel Motor fixation	16
Step 7: Power Button fixation	17
Step 7-1: Fixation of the optional Power Grip (accelerator throttle)	18
Step 8: Insert the battery into the battery holder.....	18
Step 9: Initial startup.....	18
Fixation of the ONwheel bag.....	19
Use of the ONwheel App	20
Setting up a connection with the ONwheel.....	20
Power/Speed control by app.....	20
Firmware Updates.....	21
Manual calibration of tire diameter.....	21
System Info.....	21
Power Button options	21
Care and Maintenance	22
Loading the battery with the charger	22
Care instructions	22
Troubleshooting.....	23
Technical specifications	25
Warranty	26

Safety Instructions

Speed Control



The user is responsible that the ONwheel motor may be operated only within the extent permitted by law regulations in each country. Because different laws from country to country, it is the responsibility of the user to obtain information on the legal regulations before using the device.



We expressly point out that the activation of a higher power/speed than the preset 25 km/h and 250W, is the responsibility of the user and may only be done in accordance with the legal regulations in each country.

Working with the ONwheel

Note that the ONwheel is not suitable for children under 12 years and for children's bicycles.



CAUTION - RISK OF INJURY!

The ONwheel has moving parts that can cause injury if used improperly. Never touch the ONwheel Motor in switched-on state. Take extra care that you don't put your hands or other body parts between the tires and drive roller, as this can lead to serious injuries.

Make sure, that nothing can be wedged between the ONwheel motor and the rear tire, objects falling down from your bike, clothing or other subjects, as this could lead to blockage of the rear wheel.

Make sure that the motor swing is always free to move and no objects can become wedged therein. A blocked motor swing may have the consequence that the engine can't be detached from the rear tire and it can lead to a fall in the worst case.

Please don't attach/detach the ONwheel motor to/from the mounting plate when the battery is switched on. Switch off the battery everytime when the ONwheel is not in use.

Keep the ONwheel Complete Kit always out of reach of children.



ATTENTION!

Please never let the ONwheel unattended in switched-on state.

Working with the battery

Keep and load the battery out of the reach of children and store it frost-free and in a dry place. Don't expose the battery to greater heat.

Don't use a damaged or dead battery. The battery is declared dead if the capacity can't reach more than 70% of the previous capacity. Usually that is the case after about 900 – 1,000 charge cycles.



Damaged or dead batteries are not allowed to be thrown away into household garbage. Please contact your local trash management for proper disposal or send the battery back to us, so that we can dispose it accordingly.



ATTENTION!

Don't open the battery housing under no circumstances. The battery consists of Li-Ion battery cells, as well as electronic components for controlling of charge and discharge. Opening or damaging of the battery housing may cause short circuits and could lead to inflaming of the battery cells.

Working with the battery charger

Keep the battery charger in a dry place. Don't expose the battery charger to temperatures over 80°C. Take care, that the cables are stored kink free. Before every startup, make sure that no cables are damaged. Damaged cables have to be replaced immediately.

The battery charger is suitable for an input voltage of 110V – 230 V at 50 – 60 Hz and the maximum output voltage is 25,2 V.

Use the battery charger only for the charge of the ONwheel battery. The charging of other appliances or batteries may lead to unwanted damage and fire.

Working with the Power Grip (accelerator throttle)

First mount the Power Grip (accelerator throttle) as described in the Step 7-1: Fixation of the Power Grip (accelerator throttle).

For the use of the Power Grip you have to set the power level 0 on the Power Buttons. Then remove the protecting cap from the 3.5mm jack socket at the left side of the Power Buttons and connect the Power Grip cable.

Your bike has to reach a speed of 6 km/h for the start of the ONwheel motor and for the use of the Power Grip. With the help of the Power Grip you can regulate the speed of your bike smoothly up to your set maximum speed. (standard – 25 km/h)



The driving of your bike only with the Power Grip (accelerator throttle) without pedaling, is not allowed in the most countries because of legal reasons. Please inform yourself exactly, before you activate this special setting in the go-e ONwheel app.

CE-Declaration of Conformity



Harmonised standard: EN 15194:2009 + A1

EMC interference emission and immunity

DEVICE UNDER TEST

Designation/Type: ONwheel
Manufacturer: go-e GmbH
Satellitenstraße 1
9560 Feldkirchen in Kärnten
Austria
Serial Number: OW-01-16-V3
Manufacturing Date: 04.2016

Brief description / Function / Components

The device under test is an electric power supply unit for bicycles as pedelec version. The motor is designed for retrofitting and is mounted instead of the bicycle stand.

Motor:

Nominal torque: 4,0 Nm
Nominal performance: max. 600W (250 W standard setting)
Nominal voltage: 22,5V

Signed for and behalf on:

Feldkirchen in Kärnten

11.05.2020

Place and Date

go-e
GmbH

Satellitenstraße 1
A-9560 Feldkirchen
www.go-e.co

Pete Pötzi, CTO go-e GmbH

Machinery Directive

At the beginning of 2010 the European Commission has confirmed that cycles with pedal assistance, equipped with an auxiliary electric motor, are just allowed to have a maximum continuous rated power of 0.25 kW, which is progressively reduced with increasing speed and by reaching a speed of 25 km/h or sooner or if the cyclist stops pedaling, the motor gets interrupted. This falls under the scope of Directive 2006/42/EC (Machinery Directive).

This Directive contains a list of the essential health and safety requirements in connection with the design and construction of machinery, i.e. pedelecs. Vehicles may only be placed on the market and/or put into service if they meet these requirements.

Since the ONwheel represents an incomplete machine in the sense of the Machinery Directive 2006/42/EC, it is the responsibility of the bicycle operator to ensure that the equipment guidelines, in accordance with DIN EN 15194, are kept with the mounting onto the bicycle and with the use of electrically powered bicycles.

Delivery contents

Included in delivery

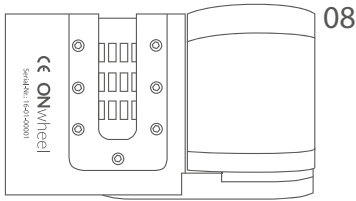

1 x ONwheel motor

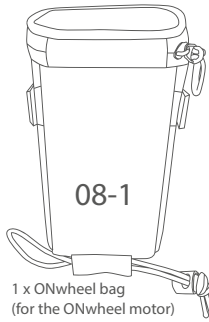

1 x ONwheel bag (for the ONwheel motor)

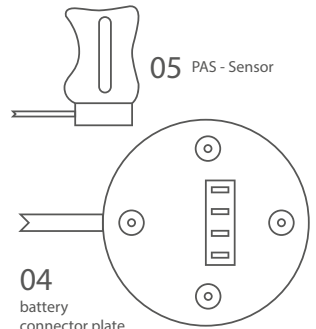

1 x allen screw 26mm x 10mm



1 x serrated lock washer

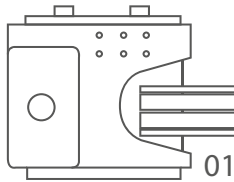

1 x mounting plate



1 x allen screw 12mm x 2mm



4x cross-headed screw 7mm x 2mm

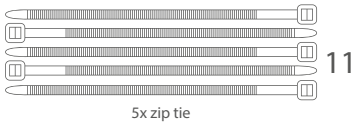

5x zip tie



2 x allen screw 16mm x 5mm



2 x battery holder keys

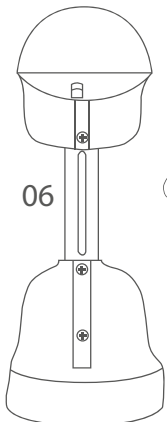

1 x ONwheel battery holder

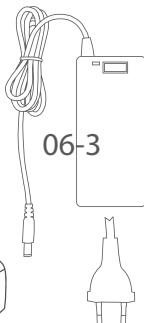

1 x ONwheel battery charger

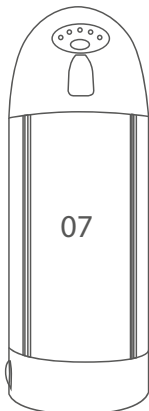

1 x ONwheel battery

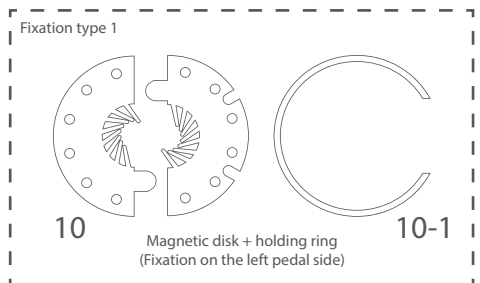
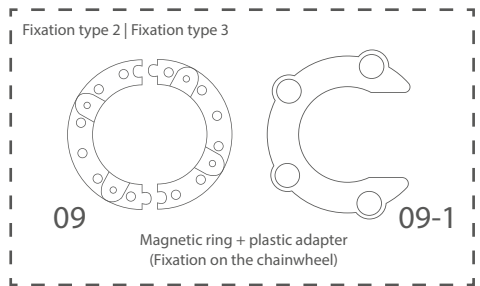

Optional available products

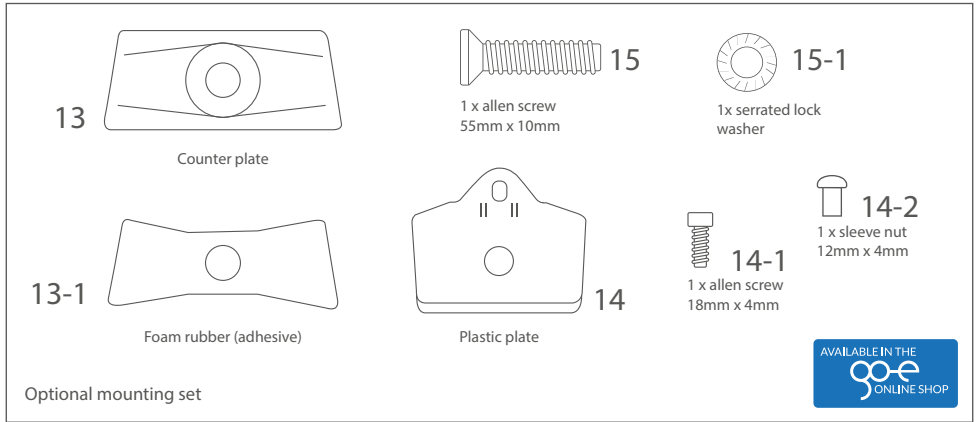

13 Counter plate

13-1 Foam rubber (adhesive)

14 Plastic plate

15 1 x allen screw 55mm x 10mm

15-1 1x serrated lock washer

14-1 1 x allen screw 18mm x 4mm

14-2 1 x sleeve nut 12mm x 4mm

Optional mounting set

AVAILABLE IN THE
go-e
ONLINE SHOP

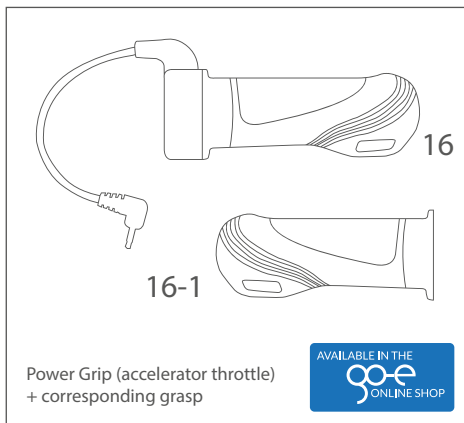

16

16-1

Power Grip (accelerator throttle)
+ corresponding grasp

AVAILABLE IN THE
go-e
ONLINE SHOP

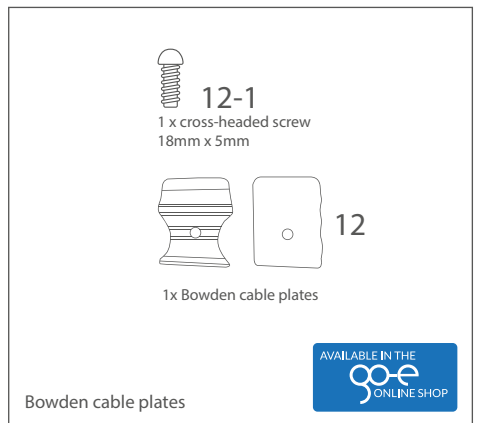

12-1 1 x cross-headed screw 18mm x 5mm

12

1x Bowden cable plates

Bowden cable plates

AVAILABLE IN THE
go-e
ONLINE SHOP

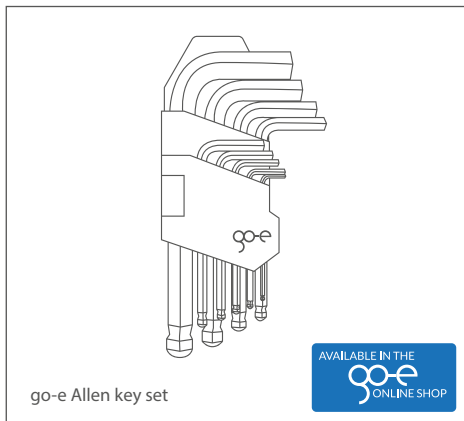

go-e Allen key set

AVAILABLE IN THE
go-e
ONLINE SHOP



go-e Smartphone bag

AVAILABLE IN THE
go-e
ONLINE SHOP

Mounting and setting up the ONwheel Complete Kit

Preparation of mounting



Before installation, we recommend a thorough cleaning of your bicycle, in particular the areas which are intended for the mounting, such as the bicycle frame and the chain rings.



Charge the battery full with the provided battery charger. Please note, that the full capacity is reached after the first 4 – 5 charge cycles. You can find more information in the Care and Maintenance section.

You need following tools for mounting:



Allen key 8mm
Allen key 6mm
Allen key 4mm
Allen key 3mm
Allen key 2mm



Cross-tip screwdriver

Step 1: Mounting plate fixation

If available, first remove your kickstand from the kickstand mounting plate [P01], which is situated between the bottom bracket and the rear wheel.

Screw on the mounting plate 01, with the cables aligned into the driving direction, with the Allen screw 01-1 and pinned serrated lock washer 01-2 onto the bottom side of your kickstand mounting plate. [P02] Please take care that the mounting plate 01 is mounted twist-free.

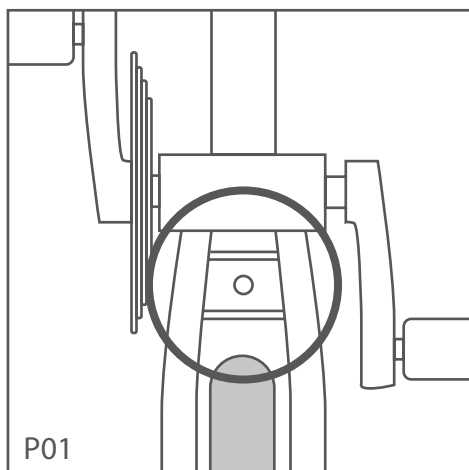

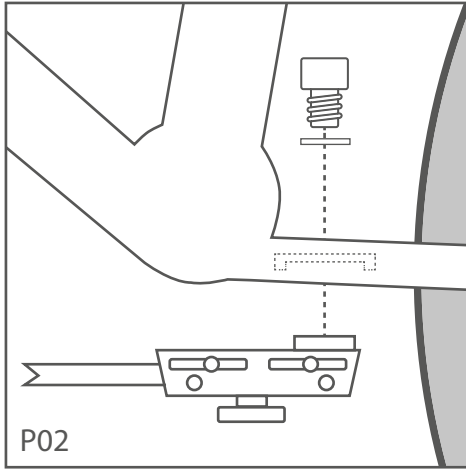

Alternative fixation of the mounting plate 01

If your bike has no kickstand mounting plate, but a cross pipe [P03] between the bottom bracket and the rear wheel, you can use the optional mounting set for mounting of the mounting plate 01.

Mount the plastic plate 14 together with the Allen screw 14-1 + sleeve nut 14-2 onto the bottom side of the cross pipe aligned into driving direction [P04].

Stick the foam rubber 13-1 onto the counter plate 13. Put the counter plate 13 onto the top of the chain stay. Plug the Allen screw 15 with pinned serrated lock washer 15-1 through the counter plate 13 and the plastic plate 14. Now you can screw the mounting plate 01 with the cables aligned into the driving direction onto the bottom side [P05].

Please take care that the mounting plate 01 is mounted twist-free.

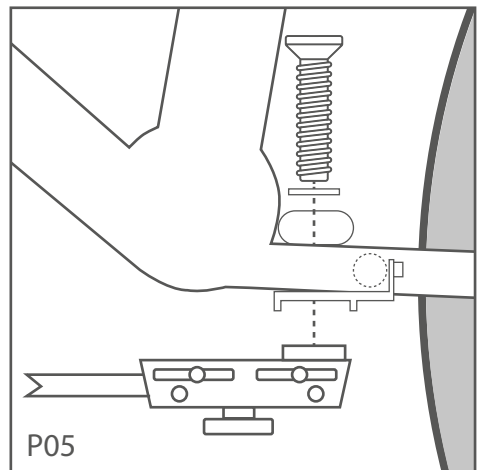
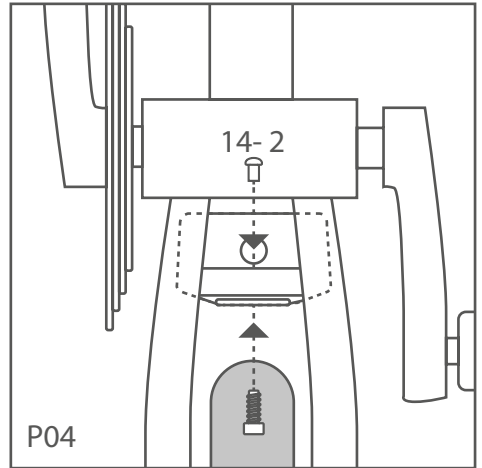
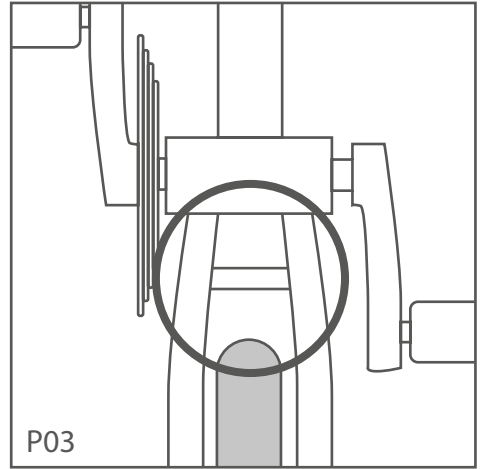

Step 2: Speed Sensor fixation

Take the cable of the speed sensor 02 and wrap it around the rear strut [P06]. Stick on the speed sensor 02 into the direction of the spokes of the rear wheel [P07]. Fix the speed sensor 02 as well with two zip ties 11 through the bushing of the speed sensor 02.

Unscrew the speed sensor magnet 02-1 [P08] and fix it onto the spoke of the rear wheel in the height of the speed sensor 02.

Take care, that the speed sensor magnet 02-1 is passing by the speed sensor 02 in the outer third to ensure a working measurement. [P09]

Fasten the speed sensor magnet 02-1 onto the right position at the spokes of the rear wheel.

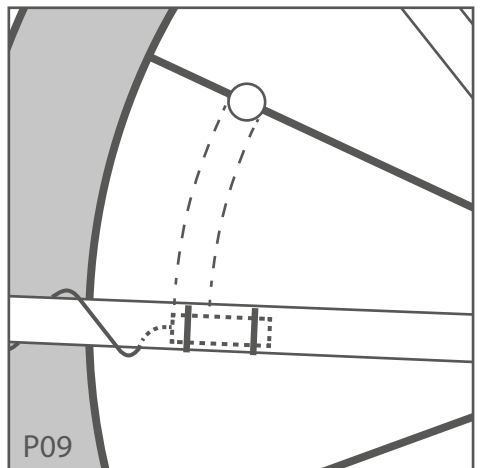
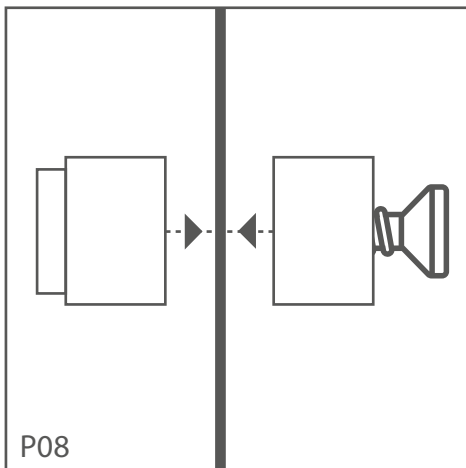
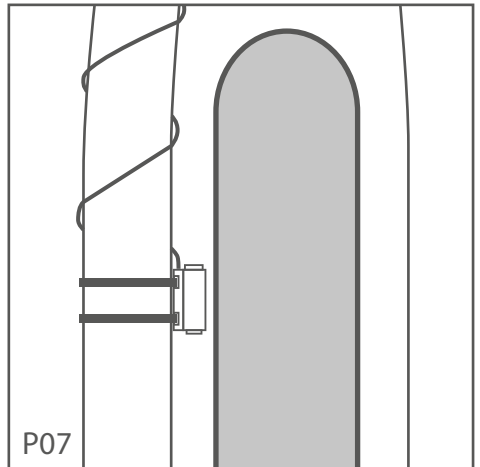
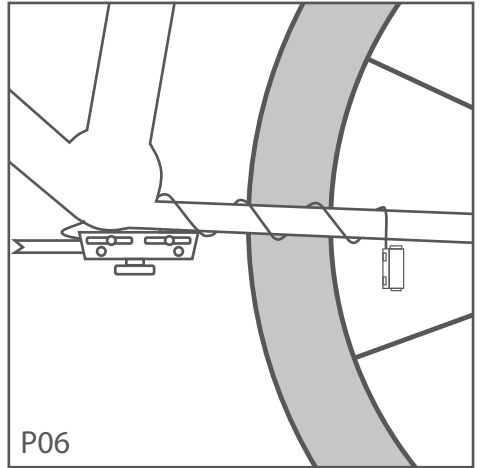

Step 3: Battery holder fixation

Screw the battery connector plate 04 with the cross-headed screws 04-1 onto the bottom side of the battery holder 06. [P10]

Mount the battery holder 06 with the two Allen screws 06-1 onto the place of the bottle holder on your bike frame. Make sure, that the cables from the battery connector plate 04 are not layed on the side of the chain wheels. [P11]

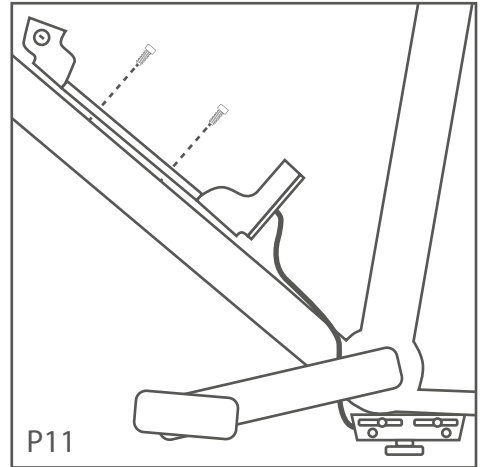
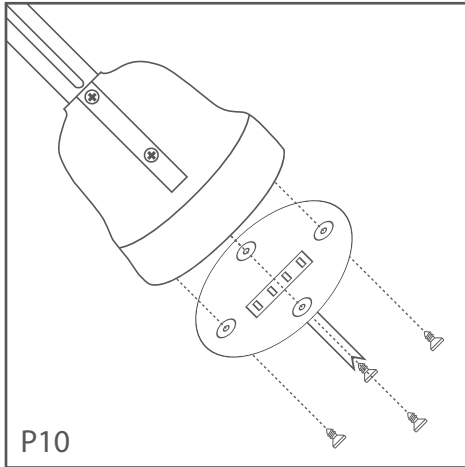

Step 4: Laying the Power Button cable

Take the Power Buttons 03 cable and lay it along your bottom pipe of your bike frame up to the right side of the handlebar. [P12] For the fixation you can use zip ties 11.

Please screw on the Power Buttons 03 only in Step 7, because they could get damaged in the further steps.

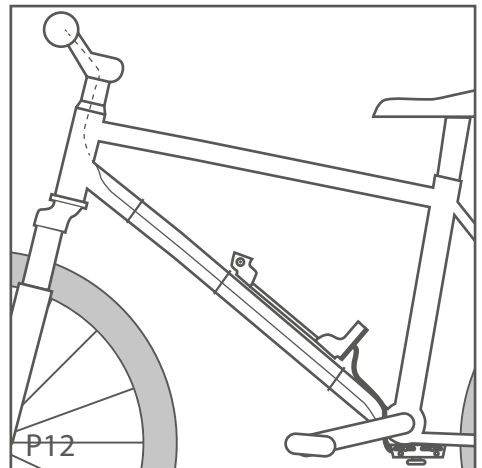

For the further steps we recommend to rotate your bike. Make sure, that no components can get clamped/damaged during rotation of your bike.



Step 5: PAS-Sensor - magnetic ring/magnetic disc fixation

Depending on your chosen mounting direction, you get either the magnetic ring 09 + plastic adapter 09-1 or the magnetic disk 10 + holding ring 10-1.

Fixation type 1:

Fixation with magnetic disk 10 + holding ring 10-1

This fixation type takes place on the left bike frame side (opposite of the chain wheels).

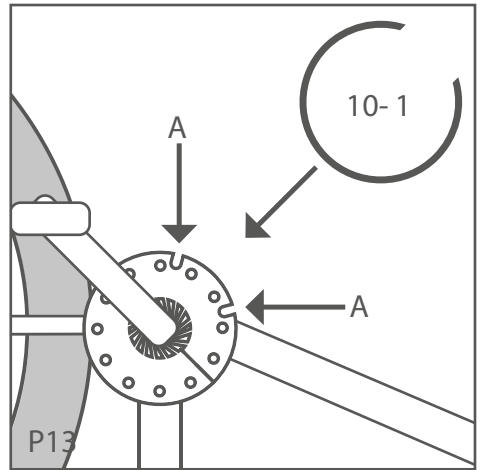

Put together the two parts of the magnetic disk 10 between the crank and bottom bracket with the "Working Surface" side facing to the bike frame. Press the magnetic disk 10 in direction of the bike frame to straighten it. [P13] Pull the holding ring 10-1 over the magnetic disk 10 for fixing. Don't overlap the notches [P13-A] on the magnetic disk 10.

Stick the PAS-Sensor 05 in max. distance of 5mm facing into direction of the magnetic disk 10 onto the bottom of the bottom bracket on your bike frame. [P14]

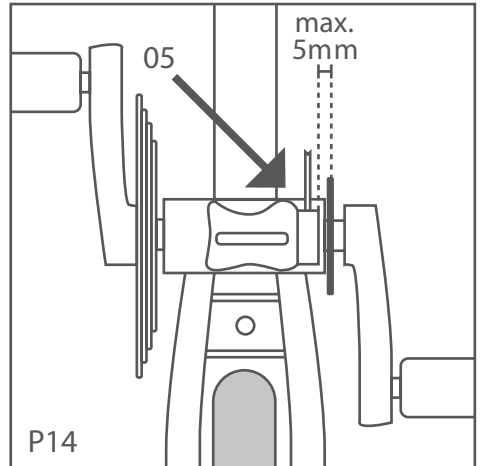

Fixation type 2:

Fixation with magnetic ring 09

This fixation type takes place on the chain wheel side with a 64-BCD¹ bolt circle chainring (with 4 screws).

The magnetic ring 09 gets mounted onto the smallest sprocket wheel of the chainring. [P15] First you mount the one part then the other.

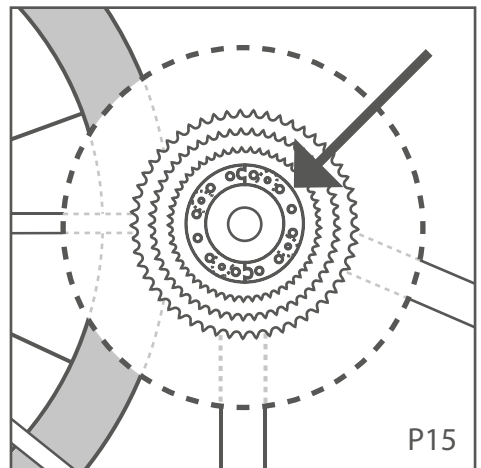

¹ - Refers to the bolt circle diameter of the chainring bolts

The magnetic ring 09 should be held on position by the magnets. If you are unsecure if the magnets really hold on the ring, you can stick on the magnetic ring 09 with some drops of super glue.

Stick the PAS-Sensor 05 in max. distance of 5mm facing into direction of the magnetic ring 09 onto the bottom of the bottom bracket on your bike frame. [P16]

Fixation type 3:
Fixation with magnetic ring 09 + plastic adapter 09-1

This fixation type takes place on the chain wheel side with a 74-BCD¹ bolt circle chainring (with 5 screws).

Stick the plastic adapter 09-1 with some drops of super glue onto the smallest sprocket wheel. The big holes on the plastic adapter 09-1 fit perfectly over four of five screws of the chain-wheel. [P17]

After the super glue has dried the magnetic ring 09 gets also glued onto the small pins of the plastic adapter 09 with the deepening of the magnetic ring 09 facing to them. [P18]

Stick the PAS-Sensor 05 in max. distance of 5mm facing into direction of the magnetic ring 09 onto the bottom of the bottom bracket on your bike frame. [P16]

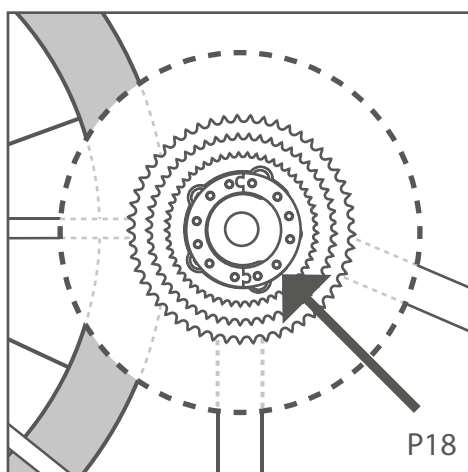
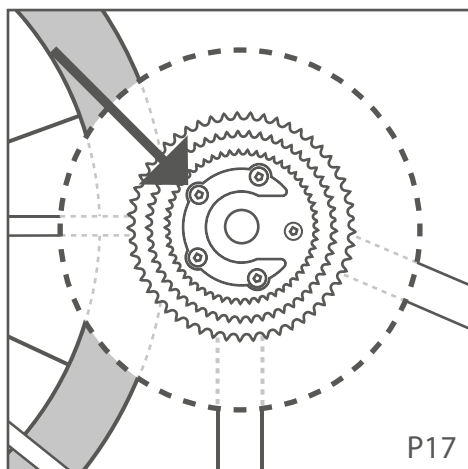
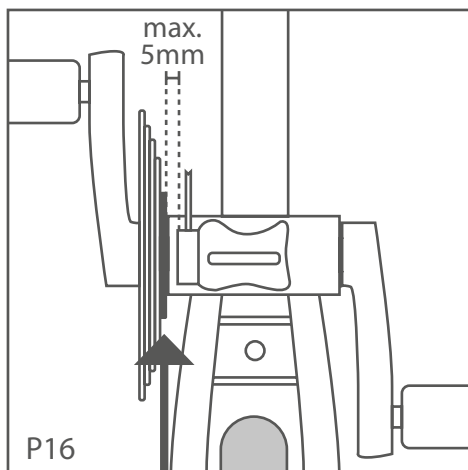

Step 6: ONwheel Motor fixation



ATTENTION

Don't have the battery in switched-on state or inserted into the battery holder during the mounting in no circumstances!

Before mounting of the ONwheel motor 11, please ensure that the rear wheel has enough tire pressure (see on tire imprint). Normally that are 3 bar.

You have to readjust the ONwheel motor 11, when your rear wheel loses tire tread over the time or when you have mounted a new rear tire.

Put on the ONwheel Motor 11 onto the slide of the mounting plate 01 till it locks imperceptible.

Unscrew the two screws of the lengthwise adjustment of the mounting plate 01. [P19] Now press the ONwheel motor 11 with power towards the rear wheel and at the same time fasten the screws of the lengthwise adjustment. [P20]

Check, if the drive roller of the ONwheel motor 11 is pressed enough against the rear wheel. Ideally, the shell of the rear wheel should get slightly pushed in.

To check if the ONwheel motor 11 is positioned correctly, hold the drive roller and try to rotate the rear wheel. The rear wheel may not move.

Additionally, you can activate the automatic switch-off at too much loss of tire tread. For more info, see section Use of the ONwheel App.

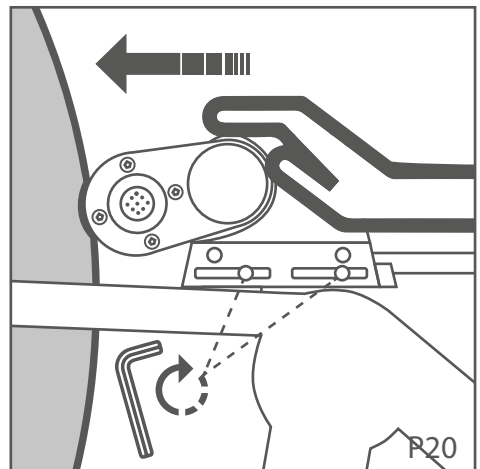
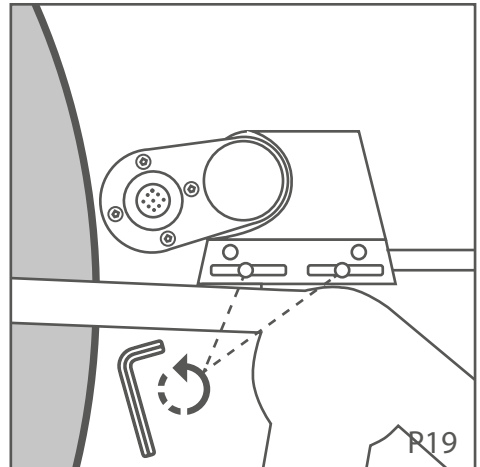



If the ONwheel motor 11 gets mounted improperly, it could lead to damage of the motor and rear wheel.

For the final mounting steps you can rotate back your bike to normal position.



Step 7: Power Button fixation



At temperatures under 10°C you should heat up the Power Button 03 holder with a hair dryer to prevent damage by bending of the holder.

For the fixation of the Power Buttons 03 you can bend the holder to get it over your handlebar. [P21]

Screw on the Power Buttons 03 with the Allen screw 03-1 on the right side of your handlebar, only so you can use the USB- and Power Grip (accelerator throttle) jacks properly.

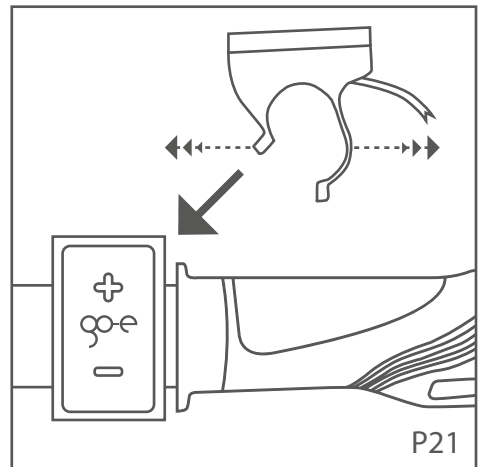

To prevent a rip out of the bolting of the plastic holder, don't screw on the Allen screw 03-1 too hard.

Step 7-1: Fixation of the optional Power Grip (accelerator throttle)



For easier fixation of the grasps onto the handlebar, we recommend to soap the grasp areas on the handlebar and of the inside of the grasps with detergent.

First remove your old grasps on your handlebar of your bike. Pull the left grasp over the handlebar, then pull the Power Grip (accelerator grip) over the right side of the handlebar and fasten the already mounted Allen screw of the Power Grip.

Remove the protecting cap from the 3.5mm jack on the left side of the Power Buttons 03. You can plug in the Power Grip (accelerator throttle) into this jack.

The Power Buttons 03 will get deactivated when you plug in the Power Grip. Before you plug in the Power Grip you have to switch to the power level 0 (Power Grip mode) over the Power Buttons 03 and afterwards push through the plugged in Power Grip once in order to activate it.



The driving of your bike only with the Power Grip (accelerator throttle) without pedaling, is not allowed in the most countries because of legal reasons. Please inform yourself exactly, before you activate this special setting in the go-e ONwheel app.

Step 8: Insert the battery into the battery holder

Insert the battery 07 into the battery holder 06. The battery 07 should snap in to the battery holder 06 completely.

Step 9: Initial startup

Switch on the battery 07 on the left side at the on-off switch. The ONwheel system starts and checks the 3 phases of the ONwheel motor and at successful test, three signals sound for each phase, followed by the 'go-e' acoustic signal.

For performing of a motor and speed-sensor calibration it's enough to drive a short distance of 100m with a speed of 15 – 20 km/h by your bike. The ONwheel motor gets automatically calibrated to your rear wheel size.

As second option you can activate the manually measurement of the rear wheel diameter in the app. See section Use of the ONwheel App for more Info.

The ONwheel complete kit gets delivered with the factory setting of 250W and 25 km/h. In order to adjust the power/speed you need a smartphone with Bluetooth and the go-e ONwheel app installed.

For the function testing of the ONwheel complete kit, you can use the System Info in the ONwheel App.

After you have finished all steps successfully you can go around with your ONwheel. Please note, that the ONwheel motor needs a minimum speed of 6 km/h to get activated. The ONwheel motor swings on to the rear wheel and pushes your bike forward.

How fast the motor pushes you forward, you can set on the Power Buttons on your handlebar. At the level 0 the motor is in passive mode/power grip mode. At the levels between 1 and 4 you can regulate the speed in steps of 25% with each level.



The ONwheel motor detects automatically your pedaling speed and adapts the switch on-off state to your pedaling behavior. If you stop pedaling the ONwheel motor also stops.

Fixation of the ONwheel bag

The ONwheel bag 08-1 gets mounted under the bike seat onto the two struts and on the front side on the saddle tube. [P22]

Open the two hook and loop fastener on the sides of the ONwheel bag 08-1 and put them through the gaps between the seat and the struts and close them again on the sides of the ONwheel bag 08-1.

Take the textile elastic band on the front and pull it through each other and tighten it.

You can use the ONwheel bag 08-1 to store your ONwheel motor securely.

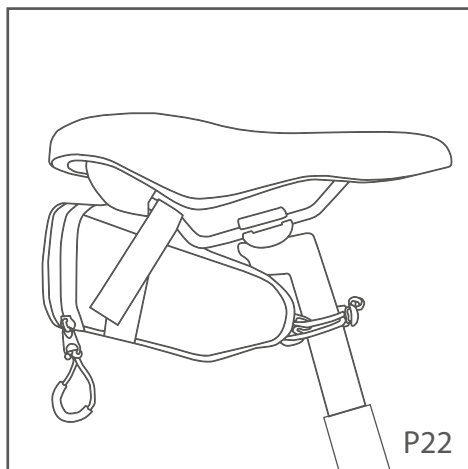

Use of the ONwheel App

Download the go-e ONwheel App at the Google Play Store or from the Apple App Store.

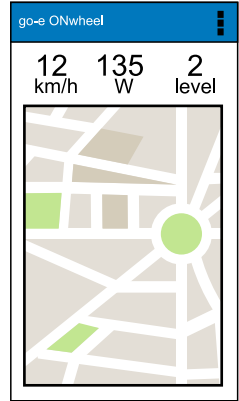

The app helps you to monitor the ONwheel complete kit and to make power/speed settings. For easier navigation of your bike trips a Google Map is also integrated.

Setting up a connection with the ONwheel

The ONwheel motor has a built in Bluetooth module with which you can connect to the ONwheel motor over your Bluetooth capable smartphone and the go-e ONwheel App.

Start the go-e ONwheel App and pair your ONwheel motor over Bluetooth with your smartphone. After successful connection establishment the system status changes to Online and the most important system info shows up.

Power/Speed control by app



It's the responsibility of the bicycle owner to know and observe the local regulations for bicycles with electric drives. A violation of local laws may result in criminal penalties.

The Power/Speed control settings can be found in the country settings of the ONwheel App. Please note, that the power/speed settings need an activation by activation code.



First you have to accept the terms & conditions for the power/speed settings, then you can choose your desired power/speed setting.

You can request an activation code in the app. This activation code has to be typed into the field "Activation code" and submitted by clicking on the "OK" button. Now you have made the new settings.

If you desire to change these settings again, then please repeat the part Power/Speed control by app.

Firmware Updates

From time to time we are releasing firmware updates that can be installed with help of the ONwheel app.

Your ONwheel motor has to be paired over Bluetooth with your smartphone. At startup, the ONwheel app searches for new firmware updates and gives you a notification if a new one is available, so you can install it at the same time or at a later moment.

Manual calibration of tire diameter

The ONwheel motor detects the tire diameter automatically, but you can also make use of the manual setting of tire diameter for more precise measurement of the speed.

If you have set the manual calibration of tire diameter, the ONwheel motor deactivates automatically at too much wheel spin (speed difference) between the drive roller and rear wheel. Therefore, the ONwheel motor will not function as desired if the tire diameter is measured and typed in incorrectly or mounted onto another bike with other tire diameter.

System Info

The System Info screen shows you detailed information about your ONwheel complete kit. These can be found in the menu System Info.

With help of these you may find and solve possible errors of your ONwheel complete kit or you can use these as an indicator in the case you have to call the support.

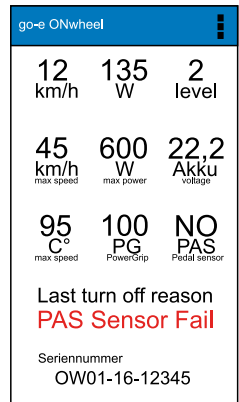

Power Button options

You can set the Power Buttons as you wish. These option you can find in the menu Speed/Power. Depending on the set maximum power/speed of your ONwheel complete kit (standard 25 km/h | 250W) you can adjust the power/speed levels randomly.

The level 0 is provided for deactivating of the ONwheel complete kit or for the activation of the Power Grip mode. On the main page of the app you can see in which level you are. Furthermore, detailed information you can find in the System info menu.

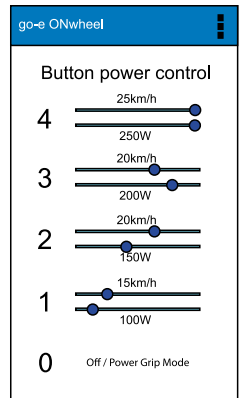

Care and maintenance

Loading the battery with the charger

For loading of the ONwheel battery 07, please use the delivered ONwheel battery charger 06-3. Switch on the ONwheel battery charger 06-3 to the power supply and the other end to the ONwheel battery 07. The charging port is under the protecting cap on the right bottom side of the ONwheel battery 07.

The indicator lamp of the ONwheel battery charger 06-3 is red during the charging and at finished charging it's going green. The charging takes up to four hours, depending on the previous charge level.

The lithium-ion technology of the ONwheel battery 07 makes it possible to smoothly charge and discharge the battery at any time, because of no memory effect.

However, we recommend to charge the ONwheel battery 07 completely full for the first five charging's to reach the full charge capacity. The battery can also be charged and discharged partially.



Please attend the general warnings for the use and charge of lithium ion batteries. Don't charge your battery without your attendance.

Care instructions

The ONwheel complete kit doesn't need a special care or maintenance. However, the drive roller should be cleaned from dirt after every drive and should be stored in a dry place. For the cleaning of the ONwheel motor you can use a garden hose with a smooth water jet.



The ONwheel motor is not suitable for cleaning with a high-pressure water blaster.

Don't touch the spring contacts on the top of the ONwheel motor. Damaged spring contacts may lead to irreparable failures.

Damage through improper handling and changes done to the ONwheel complete kit are not covered by the warranty. More information can be found in the Warranty section.

Troubleshooting

The start signals sound, but the motor doesn't start.

If the motor was disabled by the '-' button on the Power Buttons, then try to turn it on by pressing on the '+' button.

Make sure, that the ONwheel Motor 11 is positioned correctly on the slide of the mounting plate 01. The ONwheel motor 11 has to be inserted up to the marking line.

Check with the help of the app, if the driving speed (km/h) is getting measured. If not, then check if the Speed Sensor magnet 02-1 is positioned correctly on the rear wheel.

Make sure, if the Power Grip (accelerator throttle) is plugged-in. If yes, the ON-wheel motor 08 will only get activated, when the Power Grip gets operated and the level 0 is set with the Power Buttons 03.

The PAS-Sensor doesn't function.

Check the proper functioning of the PAS-Sensor 05 by rotating the pedals counterclockwise. The PAS-Sensor 05 has a red control light, which is flickering counterclockwise and glows continuous in the clockwise way.



The ONwheel motor could get activated during the test! Make sure, that no body parts, clothing etc. can get caught, as this may lead to serious injuries.

If this is not the case, then check the right mounting direction of the PAS-Sensor 05 and the right distance between the PAS-Sensor 05 and the magnetic disk 10 or magnetic ring 09.

The ONwheel works, but the drive roller falls down every time from the rear wheel.

The motor deactivates after reaching of the pre-configured speed from the rear wheel (standard 25 km/h) or under the speed of 6 km/h.

That's a desired reaction and prevents, that the motor speeds up your bike more than the pre-set speed. Furthermore, the motor releases your rear wheel and enables you to drive faster without motor power.

The drive roller falls down anyway or doesn't even fold up.

Check, if the distance between motor and rear wheel is correct (to little or to many distance may cause this problem).

Check, if the motor runs flawlessly on the highest level. If yes, then your battery is empty or the drive roller got messy.

If the drive roller of the switched on ONwheel motor can't get rotated easily, then you have to clean the drive roller as explained in the Care and maintenance section.



You have to readjust the ONwheel motor 11 in case of high loss of tire tread or if you have mounted a new rear wheel.

No start signals sound.

Check if the battery is inserted properly, if it's fully charged and if it's switched on.

Try to connect an USB device to the USB port on the left of the Power Buttons and check if there is power coming out.

If there is power coming out, but no start signals sound, then please get in touch with the customer support.

www.go-e.bike/support

Technical specifications

ONwheel motor

L x W x H	125mm x 76mm x 55 mm
Height incl. mounting plate 01	75 mm
Weight motor / mounting plate 01	910g / 310g
Max. power input	Standard: 250W after activation: 800W (peak), 600W (steady)
Power input	22,2 V (nominal), 25,2 V (maximal)
Power (battery)	max. 35 A
Torque	Motor directly: 4 Nm Forms a gear transmission with the rear wheel, so it's not comparable with hub drives.

ONwheel battery

Length / diameter	268 mm / 96 mm
Diameter incl. battery holder	108 mm
Weight	1900 g
Technology	Li-Ion
Cell manufacturer	Samsung
Voltage	22,2 V (nominal), 25,2 V (Ladespannung)
Energy value	200 Wh
Capacity (Ah)	6S4P (6 cells in series-connected, each 4 cells parallel).

ONwheel battery charger

L x W x H	110mm x 50mm x 30mm
Weight	245g
Power input	100 – 240 V AC 50/60 Hz
Power output	DC 25.2 V, 2.0 A

Only suitable for indoor use. Protect from moisture.

Warranty

In relation to the customer, in cases of defects of the delivered product, the warranty provisions (§8 Customer Protection Act) apply. No case of warranty exists for damage caused by improper use or handling of the product. The same applies to ordinary wear.

The product images on the website and/or in our print media, differ from the appearance of the delivered product, due to the resolution and size in terms of color and size. The delivered goods shall be deemed as agreed as long as the delivered pieces correspond to the product specification.

If the customer is a consumer under the Consumer Protection Act, he shall do his utmost to check the goods for completeness, correctness and other faultlessness, in particular the package integrity and shall contact us in case of any of these via email at office@go-e.bike with a brief description. This is the only rapid and effective processing of any notices of defects. A breach of this obligation does not restrict the statutory warranty rights of the consumer.

If a return of the goods is demanded by the customer and the goods are actually defective, we bear the costs. Otherwise, any costs of shipment are to be borne by the customer. Defective goods must therefore be returned only on our specific request.

Liability for contents

The contents of this user manual were issued with great care. For the accuracy, completeness and timeliness of content, we cannot take any responsibility. For setting and printing errors, we assume no liability.

This product complies with the requirements of existing EU directives. (See CE – Declaration of Conformity)



Responsible for the content

go-e GmbH
Industriestrasse 19
9560 Feldkirchen i. K.
AUSTRIA

www.go-e.co

